



FORCE SP BLOWER Owner's Manual



Patent #6,253,416 and other patents pending FORCE BLOWER Owner's Manual

F902SPH, F1002SPV, F1302SPH, F1802SPV

Beginning Serial #: 110215001

Accessories

HOLD DOWN KIT	SOLID FRONT TIRE	PARKING BRAKE	CASTER KIT
To secure blower for transportation on trailer floors.	Solid flat-free front tire.	Effective and easy to use to prevent blower from rolling.	For greater maneuverability on hard surfaces.
			
P/N 440120	P/N 440279	P/N 440140	P/N 440293

Original Instructions

IMPORTANT- READ CAREFULLY BEFORE USE AND KEEP FOR FUTURE REFERENCE



FORCE SP BLOWER Owner's Manual

CONTENTS

SPECIFICATIONS, SAFETY, AND INSTRUCTION LABELS	3
ENGINE LABELS AND PACKING CHECKLIST	4
ASSEMBLY	5
OPERATION	6
MAINTENANCE	7-8
TROUBLESHOOTING	9
MAINTENANCE RECORD	10
ILLUSTRATED PARTS AND PARTS LIST	11-13

Go to <http://www.billygoat.com> for French-Canadian translations of the product manuals.

Visitez <http://www.billygoat.com> pour la version canadienne-française des manuels de produits.



FORCE SP BLOWER Owner's Manual

SPECIFICATIONS

	F902SPH	F1002SPV	F1302SPH	F1802SPV
Engine HP	9.0 HP (6.6kW)	10.0 HP (6.6kW)	13.0 HP (9.6kW)	18 HP (13.42kW)
Engine Model	GX270K1QA2	19L2320055F1	GX390UTQAA2	3564420298F1
Engine Type	HONDA OHV	B & S VANGUARD	HONDA OHV	B & S VANGUARD
Engine Fuel Capacity	6.3 qt. (6.0L)	3.96 qt. (3.75L)	6.5 qt. (6.1L)	9 qt. (8.52L)
Engine Oil Capacity	1.16 qt. (1.1L)	0.88 qt. (0.83L)	1.16 qt. (1.1L)	1.75 qt. (1.66L)
Total Unit Weight	152 # (68.9 Kg)	164 # (74.3 Kg)	167 # (75.7 Kg)	182 # (82.6 Kg)
Overall Length	58"(1.43m)	58"(1.43m)	58"(1.43m)	58"(1.43m)
Overall Width	29.25" (0.74m)	29.25" (0.74m)	29.25" (0.74m)	29.25" (0.74m)
Overall Weight	45" (1.14m)	45" (1.14m)	45" (1.14m)	45" (1.14m)
Max Operating Angle	20°	20°	20°	25°

SAFETY



WARNING



This product can expose you to chemicals including gasoline engine exhaust, which is known to the State of California to cause cancer, and carbon monoxide, which is known to the State of California to cause birth defects or other reproductive harm. For more information go to www.P65Warnings.ca.gov.

INSTRUCTION LABELS

The labels shown below were installed on your BILLY GOAT® FORCE™ Blower. If any labels are damaged or missing, replace them before operating this equipment. For your convenience in ordering replacement labels, part numbers are included in the Illustrated Parts List. The correct position for each label may be determined by referring to the Figure and Item numbers shown.



LABEL SPARK ARRESTOR
P/N 100252



LABEL READ OWNERS MANUAL
ITEM #44 P/N890301



LABEL SAFETY PROTECT
ITEM# 45 P/N 100346



DANGER FLYING DEBRIS
ITEM # 46 P/N 810736



LABEL CLUTCH ENGAGE
P/N 500176



LABEL EXPLOSIVE FUEL
ITEM # 43 P/N 400268



LABEL OIL CHAIN
ITEM #119 P/N 830502



LABEL THROTTLE CONTROL
ITEM # 42 P/N 810656



FORCE SP BLOWER Owner's Manual

ENGINE LABELS

HONDA

■ READ OWN'S MANU BEFORE OPEION
 ■ LIRE LE MANU UTILITEUR ANT USAG
 ■ VOR INBETRIEBNAHME UNBEDINGHT BEDIENTUNGSANLEITL
 ■ NO UTILIZAR SINANTES NO HABEMANUA
HONDA MOTOR CO., LTD. MADE IN JAPAN



OIL ALERT

■ WHEN OIL LEVEL LOW, ENGINE STOPS IMMEDIATELY.

BRIGGS AND STRATTON VANGUARD

ENGINE MAINTENANCE

1. CHECK OIL LEVEL	8 HOURS
2. CHECK & CLEAN AIR CLEANER	25 HOURS
3. CHANGE OIL	50 HOURS
4. REPLACE OIL FILTER	100 HOURS
5. CLEAN COOLING FINS	100 HOURS

See Operating and Maintenance Instructions

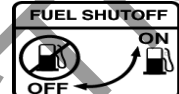

PACKING CHECKLIST

These items should be included in your carton. If any of these parts are missing, contact your dealer. Your BILLY GOAT® FORCE Blower was shipped in one carton, completely assembled except for the Upper Handle Assembly and Front Diverter. Mounting hardware for the Upper Handle Assembly can be found in the parts bag.



READ all safety instructions before assembling unit.
TAKE CAUTION when removing the unit from the box as the Handle Assembly is attached to the unit by cables.



PUT OIL IN ENGINE BEFORE STARTING.

PARTS BAG & LITERATURE ASSY

Warranty card P/N- 400972, Owner's Manual P/N-440314, General Safety and Warnings Manual P/N-100294, Declaration of Conformity P/N-440331, Handle Hardware-Items #10, #11, #74, #36, and #123.

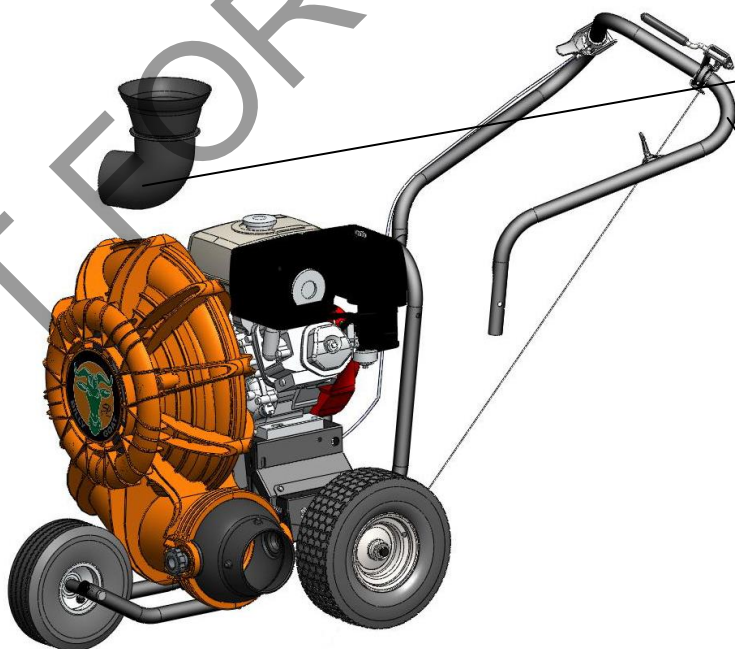

Boxing Parts Checklist

- Front Air Diverter
(For F902S, F902H, and F1302H models only)
Item#38
F9 MODELS P/N-440045-4
F13 MODELS P/N-440045-5
- Handle Upper Assembly
Item #30 P/N-440035
- Parts Bag & Literature Assy
P/N-440267
- Honda 9 or 13 hp
- Subaru 9 hp
- B & S Vanguard 10 or 18 hp



FORCE SP BLOWER Owner's Manual

ASSEMBLY

1. The hardware for attaching the upper handle to the lower is in the parts bag. Install the upper handle (item 30), to preassembled lower handle (item 28) by sliding the upper handle over and down the outside of the lower handle. Using the bolts (items #36 and #123), washers (item #10) & lock nut (item #11) to install upper handle to lower handle. **NOTE:** The Pigtail bolt should go on the side that the pull start is on and the open end should be facing down. Finish installing the other side of the upper handle assembly using screw and lock nut provided. (See Fig. 1)
2. The throttle control will be attached to the throttle arm on the engine and wrapped around the engine for shipping. Unwrap and secure throttle control (item #31) to upper handle with screws (item #39). Screws will already be mounted in handle. Simply remove and use to mount the throttle control. Secure the throttle cable and clutch cable with two Ty-wraps (item #74). The Aim-and-Shoot™ is not attached. You will need to unroll the cable and attach the ball end to the lever and seat the cable end into the hole on the saddle clamp, with the cable running through the slot. The clutch cable will also be wrapped up under the machine. Route the cable under the axle and attach it by removing the hitch pin and clevis pin and attaching it to the clutch control lever. After it is attached pull on the cable and slide it into the hole on the bracket so that it clicks into place. To keep the cable from being damaged use two ty-wraps (item #74) to secure it to the handle as shown, making sure that the cable is not rubbing against the tire. **NOTE:** the cable should be seated properly in the saddle and should follow the contours of the handle. (See Fig. 2 and 3)
3. Connect spark plug wire.

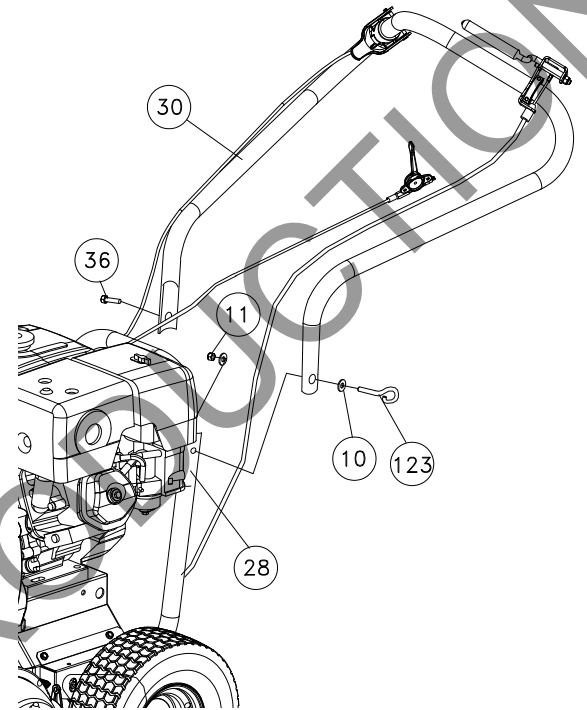

Fig. 1



Good routing



Bad routing

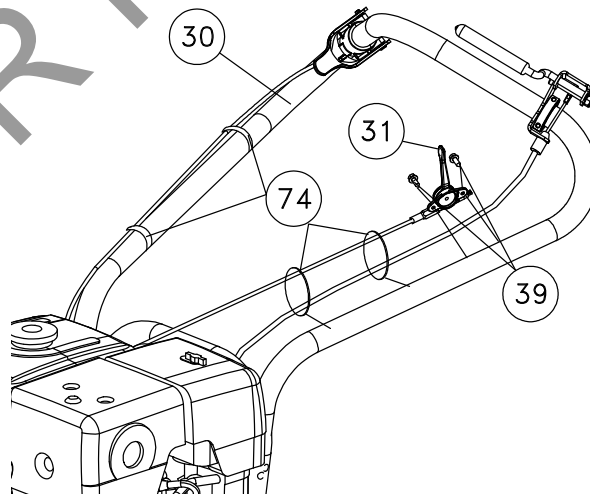

Fig. 2

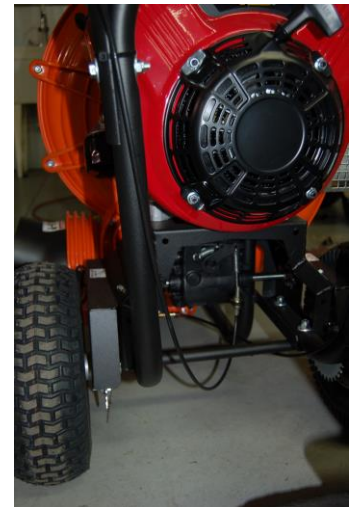

Fig. 3



FORCE SP BLOWER Owner's Manual

OPERATION

DRIVE LEVER:

To engage the clutch for forward motion, simply hold down the clutch lever with your left hand while the engine is running; this will cause the drive to engage and the machine will proceed to move forward.

⚠ Caution: It is not recommended to “feather” the drive. The drive lever should be either fully engaged or fully disengaged. Failure to do so can cause premature failure of the cone clutch in the transmission. This type of failure will void the manufacturer's warranty.

BLOWING OPERATION

Your Billy Goat Force blower is equipped with an air director cone and the patented Aim-N-Shoot™ control lever to allow the operator to direct the air stream up or down as required to assist in moving debris. This feature is extremely useful when debris has piled up to the point that it cannot be blown any farther. The air stream can be directed upward to blow the top of the debris pile over and allow the operator to continue moving more debris farther.

ADJUSTING AIR DIRECTOR

To adjust air direction, squeeze the Aim-N-Shoot control lever. When you want to blow debris at the same angle for an extended period, choose a suitable position and use the finger controlled push button lock to lock the cone in position. For operations that do not require the use of the Aim-N-Shoot feature the manual adjustment knob, pictured below, can be used to permanently lock the cone into position.

⚠ CAUTION: Be sure to release the knob when returning to using the Aim-N-Shoot.

⚠ DO NOT position director cone to where it will blow debris towards people, vehicles or other objects in vicinity. Flying debris may damage, harm, or cause injury to people or objects in air flow range.

FRONT DIVERTER POSITIONING (F9 and F13 models only)

The removable front diverter adapter can be slipped inside the cone to direct the air stream forward. First turn off engine, and then simply collapse and fold it into the larger opening of the diverter and slide inside the cone allowing it to expand. Then position to the desired angle by rotating the diverter. This option is extremely useful for cleaning out long cracks in pavement or for cleaning under bushes, building overhangs or along curbs. (See Fig. 4 and 5)

⚠ WARNING: Unit will be more difficult to control due to the air exiting the unit. Keep hands on the unit at all times when using the front diverter. Please note that the Aim-N-Shoot feature will not function when the front diverter is installed.

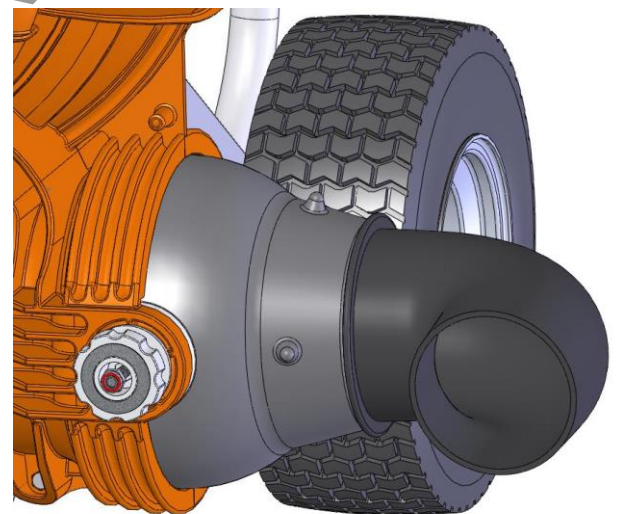
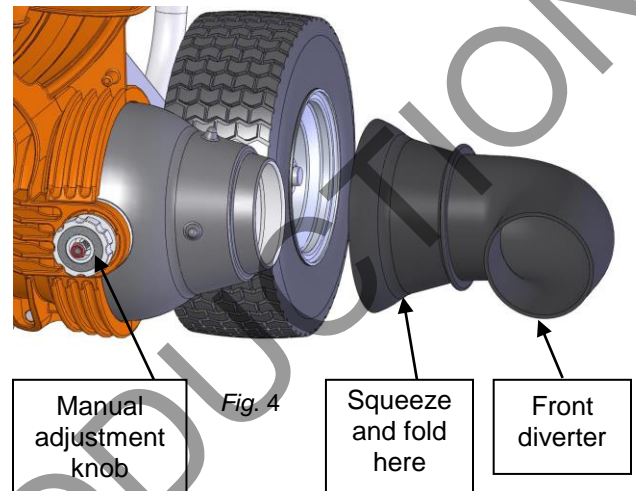



FORCE SP BLOWER Owner's Manual

MAINTENANCE

PERIODIC MAINTENANCE

Periodic maintenance should be performed at the following intervals:

Maintenance Operation	Every Use	Daily or Every 5 Hours	Every 100-150 Hours
Inspect for worn or damaged parts	•		
Check for excessive vibration		•	
Check belt/chain tightness	•		
Oil drive chain		•	
Inspect impeller for cracks or damage			•
Inspect for loose parts		•	

IMPELLER REMOVAL

1. Wait for engine to cool and disconnect spark plug.
2. Remove housing front cover by removing eleven bolts and nuts (items #13 & #14) around outside of front cover.
3. Remove impeller bolt (item #35), lock washer (item #71) and washer (item #34).
4. DO NOT pry on impeller. Pull on center hub area of impeller only. Using a penetrating oil can help loosen a stuck impeller.
5. Reinstall new impeller in reverse order of removal.
6. Tighten impeller bolt. Torque impeller bolt (see Parts List on page 13 for proper impeller bolt torque specifications).

TIRE AIR PRESSURE

Check at regular intervals and maintain.

Front Tires - 24 Psi (165 kPa).

Rear Tires - 20 Psi (137 kPa).

BELT TENSION ADJUSTMENT

DO NOT adjust while the machine is running!

1. Wait for engine to cool and disconnect spark plug.
2. Loosen the nut (item #92) on the Idler pulley (item #93) but do not remove it. This should allow the pulley to slide left or right. Once the pulley is at the proper distance to apply tension to the belt, tighten the nut. *NOTE:* Do not place too much tension on the belt, as it will cause premature failure.
3. Reattach the spark plug.



FORCE SP BLOWER Owner's Manual

BELT REPLACEMENT

1. Wait for engine to cool and disconnect spark plug.
2. Follow the impeller removal steps (2-5 on page 8).
3. Remove the four bolts (item #8) holding the back plate (item 4) to the back housing (item #6).
4. Loosen the nut on the idler pulley and slide it to the right to relieve tension on the belt. (See Fig. 6)
5. Slip the belt (item #86) off the engine pulley and the transmission.
6. Replace the belt with a new one and slide the idler pulley to put proper tension on the belt. *NOTE:* Do not place too much tension on the belt, as it will cause premature failure.
7. Reassemble the machine in reverse order. *NOTE:* You will need to replace the impeller bolt and torque to the proper specifications see page 12. **DO NOT** use the old impeller bolt.
8. Reconnect spark plug wire.

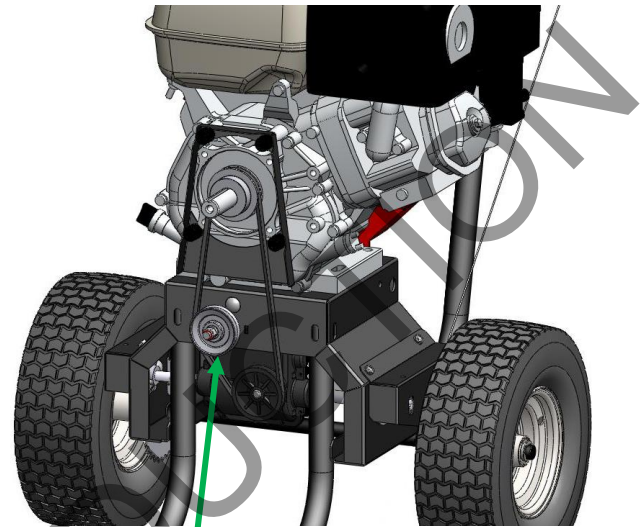

Idler Pulley

Fig. 6

DRIVE CHAIN REPLACEMENT

1. Wait for engine to cool and disconnect spark plug.
2. Place a block of wood, or another object that will support and steady the unit under the axle on the side of the machine you will be working on.
3. Remove the two screws (item #103) holding the chain guard (item #104) and then remove the chain guard.
4. Loosen the two nuts (item #98) holding the bearing (item #97). (See Fig. 7)
5. Remove the retaining ring holding the wheel on and then slide the wheel off.
6. Replace the chain (item #105). Remove the old chain by walking it off the sprockets.
7. Position the bearing so that it applies the proper tension to the chain and tighten the nuts holding the bearing *NOTE: DO NOT* over tighten the chain, as this will cause premature failure. Likewise, if the chain is too loose it will come off when the drive is engaged.
8. Reassemble the machine using steps 1-4 in reverse order.

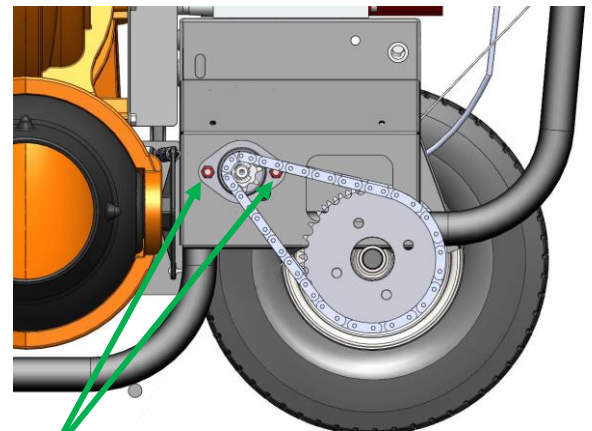

Loosen nuts

Fig. 7

CLUTCH CABLE ADJUSTMENT

1. With the machine off, loosen the two nuts on the end of the clutch cable (item #111) going in to the transmission.
2. By moving the position up or down on the threads it will change the tension on the clutch lever (item #113). *NOTE:* Do not position it too high on the threads as this could cause the drive not to engage. Likewise, if it is placed too low the drive may stay permanently engaged. The optimum setting is to remove any slack in the clutch cable when disengaged. The travel of the clutch control will apply the correct spring force on the cone clutch. Once the desired position is in place, tighten the nuts securely.
3. Start the machine and check the operation. If the drive cable is not engaging properly, shut the machine off and reposition the nuts on the cable to tighten the drive cable.



FORCE SP BLOWER Owner's Manual

TROUBLESHOOTING

Problem	Possible Cause	Solution
Abnormal vibration	Loose or out of balance impeller. Debris in impeller. Loose engine.	Check impeller and replace if required. Clear debris with compressed air or a backpack blower (see Fig. 8 and 9 below).* Check engine.
Engine will not start	Engine not in full choke position. Out of gasoline or bad, old gasoline. Spark plug wire disconnected. Gas valve off. Dirty air cleaner.	Check choke position. Check gasoline. Connect spark plug wire. Turn on gas valve. Clean or replace air cleaner. Contact a qualified service person.
Engine is locked, will not pull over	Engine problem.	Contact an engine servicing dealer for engine problems.
Aim-N-Shoot™ lever sticking	Debris stuck around cone. Cone adjustment knob too tight. Adaptor mount nut (item #38) too tight.	Clean debris. Apply silicone based lubricant to pivot points. Loosen manual adjustment knob. Loosen nut.
No self propelling	Drive lever not engaged. Drive belt worn or broken. Drive chain off the sprockets. Drive cable is out of adjustment.	Engage drive lever. Check drive belt. Check drive chain. Check drive cable (see page 9).
Self-propelled drive will not release	Improper drive cable adjustment, or cable is kinked.	Check the drive cable (see page 9).
Noisy or broken chain	No chain or lubrication. Chain tension.	Lubricate chain. Check drive chain (see page 9).

*Using compressed air, or a backpack blower, you can loosen or free debris easily from the impeller and housing, which can cause wear and tear on the machine. You can manually remove debris by taking off the front housing. Note: Always disconnect the spark plug when servicing. (See Fig. 8 and 9)



Fig. 8

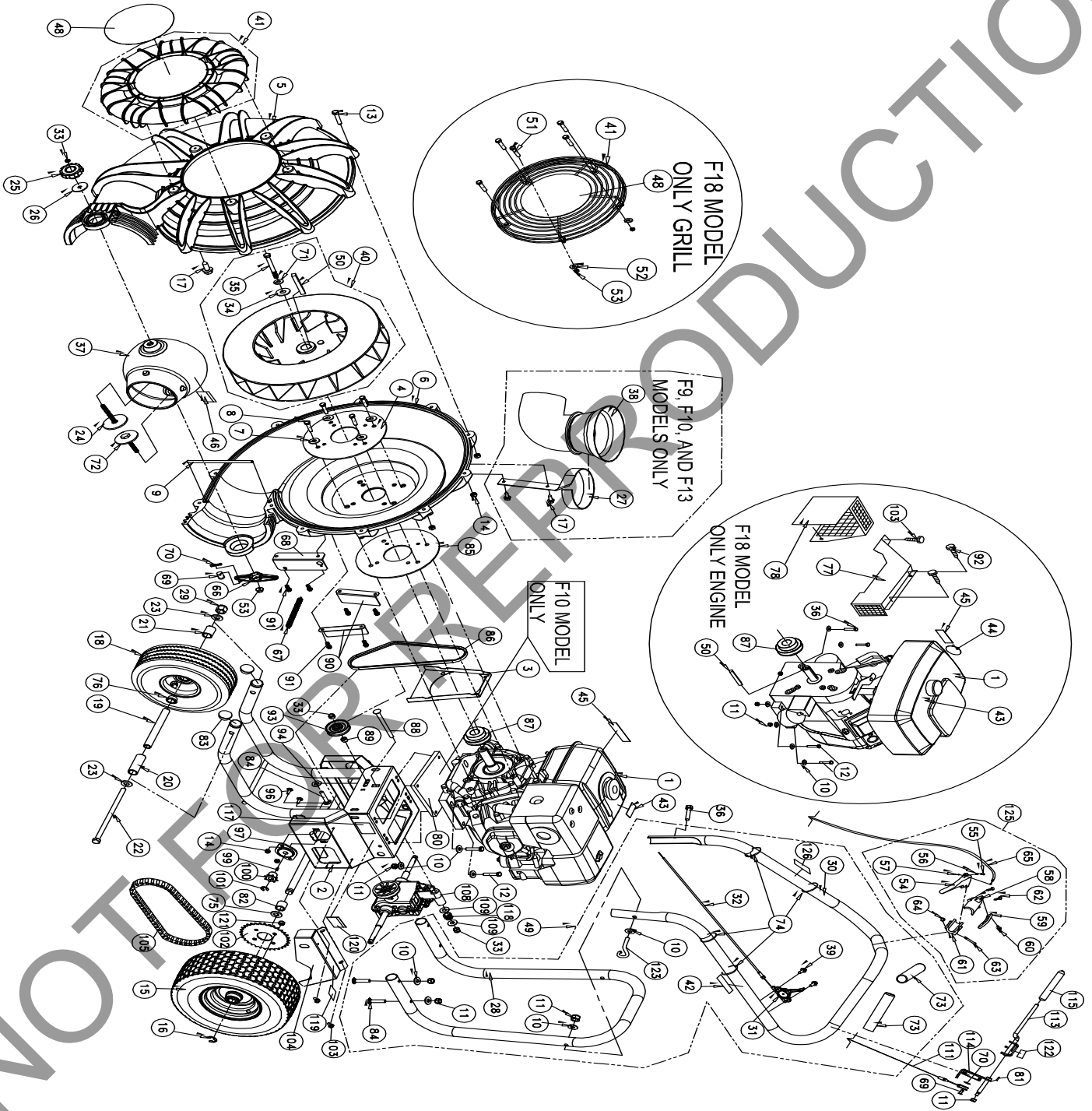

Fig. 9



FORCE SP BLOWER Owner's Manual

FORCE™ SP PARTS DRAWING





FORCE SP BLOWER Owner's Manual

FORCE™ SP PARTS LIST

ITEM NO.	DESCRIPTION	F1302SPH		F902SPH		F1002SPV		F1802SPV	
		PART NUMBER	QTY.	PART NUMBER	QTY.	PART NUMBER	QTY.	PART NUMBER	QTY.
1	ENGINE 13 HP HONDA GX390	440018	1	-	-	-	-	-	-
	ENGINE 9 HP HONDA GX270	-	-	430287	1	-	-	-	-
	ENGINE 10HP VANGUARD	-	-	-	-	440342	1	-	-
	ENGINE 18 VANGUARD	-	-	-	-	-	-	812240	1
2	BASE ENGINE WA FSP	440244-S	1	440244-S	1	440244-S	1	440244-S	1
3	GUARD BELT UPPER FSP	440209	1	440209	1	440209	1	440209	1
4	PLATE REINFORCE HOUSING	440010-P	1	440010-P	1	440010-P	1	440010-P	1
5	HOUSING FRONT MOLDED	440023	1	440023	1	440023	1	440023	1
6	HOUSING BACK MOLDED	440024	1	440024	1	440024	1	440024	1
7	WASHER LOCK 3/8 S/T MED	8177012	4	8177013	5	8177013	5	8177013	4
8	SCREW CAP 3/8-16X2 ZP	8041054	4	8041054	4	8041054	4	8041054	4
9	ROD HAND STOP	440057	1	440057	1	440057	1	440057	1
10	WASHER 5/16 FLATWASHER Z/P	8171003	14	8171003	14	8171003	14	8171003	14
11	NYLON INSERT LOCKNUT 5/16-18	8160002	11	8160002	11	8160002	11	8160002	11
12	SCREWCAP 5/16-18 X 1.75 ZP	8041031	4	8041031	4	-	-	8041031	2
	SCREWCAP 5/16"-18 X 2 3/4" GR 5 HCS ZP	-	-	-	-	8041034	-	-	-
13	SCREWCAP 1/4-20 x 1 1/2	8041008	11	8041008	11	8041008	11	8041008	11
14	NUT FLANGE 1/4-20	900455	15	900455	15	900455	15	900455	15
15	WHEEL & TIRE 13" X5" PNEUMATIC SPROCK	440219	2	440219	2	440219	2	440219	2
16	RING RETAINING 3/4	850230	2	850230	2	850230	2	850230	2
17	SCREW SM 1/4" X3/4" TYPE AB HX WF	8122082	7	8122082	7	8122082	7	-	-
18	WHEEL ASSY 10 " PNEUMATIC	400295	1	400295	1	400295	1	400295	1
19	SPACER FRONT AXLE	440220	1	440220	1	440220	1	440220	1
20	SPACER LH WHEEL FRONT	440224	1	440224	1	440224	1	440224	1
21	SPACER RH WHEEL FRONT	440221	1	440221	1	440221	1	440221	1
22	SCREWCAP 1/2-13 x 9 1/2"	8041240	1	8041240	1	8041240	1	8041240	1
23	WASHER FLAT 1/2" SAE	8172011	2	8172011	2	8172011	2	8172011	2
24	WASHER W/BOLT WA	440075	1	440075	1	440075	1	440075	1
25	KNOB 3/8-16 SOLID HUB	811230	1	811230	1	811230	1	811230	1
26	WASHER 2.25 OD x .515 ID x .134 ZP	610308-P	1	610308-P	1	610308-P	1	610308-P	1
27	BRACKET HOLDER WA	440240	1	440240	1	440240	1	-	-
28	HANDLE LOWER	440034	1	440034	1	440034	1	440034	1
29	NYLON INSERT LOCKNUT 1/2-13LT WT TH ZP	8161044	1	8161044	1	8161044	1	8161044	1
30	ASSY FORCE UPPER W/GRIPS/DECALS	440030	1	440030	1	440030	1	440030	1
31	CONTROL THROTTLE	440013	1	440013	1	440013	1	440013	1
32	CABLE THROTTLE CONTROL	440014	1	440014	1	440014	1	440178	1
33	NUT LOCK 3/8-16 LT WT THIN ZP	8161042	3	8161042	3	8161042	3	8161042	3
34	WASHER 1.5 O.D.X 0.45 I.D. X 0.5	440176	1	440176	1	440176	1	440176	1
35	SCREWCAP 3/8-24 X 3.5 GR. 8 (38 +/-2 ft-lbs.)	440151	1	-	-	-	-	-	-
	SCREWCAP 7/16-20 X 3.5 GR.8 (60 +/-2 ft-lbs)	-	-	440150	1	440150	1	-	-
	SCREWCAP 3/8-24 X 4 GR.8 (38 +/-2 ft-lbs)	-	-	-	-	-	-	8042062	1
36	SCREWCAP 5/16"-18 X 2" ZP	8041032	1	8041032	1	8041032	1	8041032	2
37	DIRECTOR CONE 5"	440044-S	1	-	-	-	-	-	-
	DIRECTOR CONE 4"	-	-	440046-S	1	440046-S	1	-	-
	DIRECTOR CONE 6"	-	-	-	-	-	-	440170-S	1
38	DIVERTOR FRONT	440045-5	1	440045-4	1	440045-4	1	-	-
39	SCREW SM #10-24X1/2" DRILL POINT	8122064	2	8122064	2	8122064	2	8122064	2
40	IMPELLER ASSEMBLY 17"	440236	1	440236	1	440236	1	-	-
	IMPELLER SERVICE ASSY FORCE 18HP	-	-	-	-	-	-	440162	1
41	GRILL FRONT BLOWER	440067-1-S	1	440067-1-S	1	440067-1-S	1	440171-S	1
42	LABEL THROTTLE CONTROL	810656	1	810656	1	810656	1	810656	1
43	LABEL FUEL EN/SP	-	-	-	-	100261	1	100261	1
45	LABEL SAFETY PROTECT READ MANUAL	100346	1	100346	1	100346	1	100346	1
46	LABEL DANGER FLYING DEBRIS	810736	1	810736	1	810736	1	810736	1
48	LABEL FORCE	440269	1	440269	1	440269	1	440269	1
49	HANDLE ASSY	440104	1	440104	1	440104	1	440104	1
50	KEY 1/4" SQ x 3 1/4	9201128	1	9201128	1	9201128	1	-	-
	KEY 1/4" SQ x 2 3/4	-	-	-	-	-	-	9201130	1
51	SCREWCAP 1/4-20 X 1" HCS ZP	-	-	-	-	-	-	8041006	5
52	WASHER FLAT 1/4	-	-	-	-	-	-	8171002	5
53	NUT LOCK 1/4"-20 HEX ZP	8160001	1	8160001	1	8160001	1	8160001	6
54	HANDLE DIVERTER FORCE	440119	1	440119	1	440119	1	440119	1
55	PIN LATCH DIVERTER	440118	1	440118	1	440118	1	440118	1
56	SPRING COMPRESSION 0.281 X 0.88	440129	1	440129	1	440129	1	440129	1
57	RING RETAINING .122 DIA	440125	1	440125	1	440125	1	440125	1
58	SADDLE LOWER DIVERTER	440115	1	440115	1	440115	1	440115	1
59	PLATE LOCK DIVERTER	440116	1	440116	1	440116	1	440116	1
60	SCREW PLASTITE #6-19 X 5/8"	440126	1	440126	1	440126	1	440126	1
61	SADDLE UPPER DIVERTER	440114	1	440114	1	440114	1	440114	1
62	SCREW PLASTITE #10-14 X 1"	440132	2	440132	2	440132	2	440132	2
63	PIN PIVOT DIVERTER CONTROL	440123	1	440123	1	440123	1	440123	1
64	RING RETAINING 5/16	430327	1	430327	1	430327	1	430327	1
65	CABLE ASSY	440117	1	440117	1	440117	1	440117	1
66	DIVERTER PIVOT ADAPTOR	440121	1	440121	1	440121	1	440121	1
67	SPRING EXTENSION 0.468 X 5.25	440130	1	440130	1	440130	1	440130	1
68	BRACKET DIVERTER FORCE	440212	1	440212	1	440212	1	440212	1



FORCE SP BLOWER Owner's Manual

FORCE™ SP PARTS LIST

ITEM NO.	DESCRIPTION	PART NUMBER	QTY.	PART NUMBER	QTY.	PART NUMBER	QTY.	PART NUMBER	QTY.
69	PIN CLEVIS 1/4 X 3/4	440124	2	440124	2	440124	2	440124	2
70	HITCH PIN CLIP .051 X 3/4"	440193	2	440193	2	440193	2	440193	2
71	WASHER LOCK 3/8 S/T MED	8177012	1	-	-	-	-	8177012	1
	WASHER LOCK 7/16 S/T MED	-	-	8177013	1	8177013	1	-	-
72	ADAPTOR MOUNT WA	440122	1	440122	1	440122	1	440122	1
73	GRIP 1-1/4" ID X 9.5" LONG	440146	2	440146	2	440146	2	440146	2
74	TY-WRAP	900407	4	900407	4	900407	4	900407	4
75	WASHER .765 ID X 1.25 OD X0.6"	850238	2	850238	2	850238	2	850238	2
76	FORCE WHEEL BEARING .751 ID	440055	2	440055	2	440055	2	440055	2
77	GUARD MANIFOLD	-	-	-	-	-	-	812243	1
78	GUARD MUFFLER SW	-	-	-	-	-	-	812410	1
80	SPACER PLATE WELDMENT	-	-	-	-	440148	1	-	-
81	ROLL PIN	8195096	1	8195096	1	8195096	1	8195096	1
82	SPACER REAR WHEEL SP	440225	2	440225	2	440225	2	440225	2
83	PLUG	791056	2	791056	2	791056	2	791056	2
84	CARRIAGE BOLT 3/8"-16 X 1 3/4" ZP	8024061	5	8024061	5	8024061	5	8024061	5
85	SPACER ENGINE FACE	440174	1	440174	1	440174	1	440174	1
86	BELT 3L29	440215	1	440215	1	440215	1	440215	1
87	SPACER HUB 1" ID X 1.25" W/PULLEY	440213	1	440213	1	440213	1	-	-
	SPACER HUB 1" ID X 1.25" W/PULLEY FSP18	-	-	-	-	-	-	440214	1
88	CARRIAGE BOLT 3/8-16 X 5" ZP	8024161	1	8024161	1	8024161	1	8024161	1
89	TUBE SPACER .625" OD X .357 LONG	440228	1	440228	1	440228	1	440228	1
90	GUARD BELT LOWER FSP	440210	2	440210	2	440210	2	440210	2
91	SCREW PLASTITE 1/4-10 X 3/4 HWH ZP	840082	6	840082	6	840082	6	840082	6
92	BOLT 1/4"-20 X 1/2" SER FLANGE	-	-	-	-	-	-	812381	2
93	PULLER VIDLER 2.5	510137	1	510137	1	510137	1	510137	1
94	WASHER 1.00" OD X .380 SQ HOLE	440227	1	440227	1	440227	1	440227	1
96	CARRIAGE BOLT 1/4"-20 X 3/4"	8024021	4	8024021	4	8024021	4	8024021	4
97	BEARING 1/2" STEEL PRESSED HOUSING	891025	2	891025	2	891025	2	891025	2
99	KEY WOODRUFF 1/8" X 1/2"	510180	2	510180	2	510180	2	510180	2
100	SPROCKET 8 TOOTH	891022	2	891022	2	891022	2	891022	2
101	RETAINING RING 1/2"	350146	2	350146	2	350146	2	350146	2
102	SPROCKET 32T #43 1.594 BORE	440218	2	440218	2	440218	2	440218	2
103	SCREW SELF TAP 1/4"-20 X 5/8"	890359	4	890359	4	890359	4	890359	6
104	CHAIN GUARD LH	440206-S	1	440206-S	1	440206-S	1	440206-S	1
	CHAIN GUARD RH	440207-S	1	440207-S	1	440207-S	1	440207-S	1
105	CHAIN #43X44 PITCHES	440217	2	440217	2	440217	2	440217	2
108	TRANS SINGLE SPEED W/CLUTCH	440216	1	440216	1	440216	1	440216	1
109	WASHER 3/8" SAE	8172009	2	8172009	2	8172009	2	8172009	2
111	CLUTCH CABLE FORCE SP	440243	1	440243	1	440243	1	440243	1
113	CLUTCH CONTROL ARM	440277	1	440277	1	440277	1	440277	1
114	CLUTCH CONTROL BRACKET	440245	1	440245	1	440245	1	440245	1
115	GRIP CLUTCH CONTROL FSP	440242	1	440242	1	440242	1	440242	1
117	SPARK ARRESTOR LABEL	100252	1	100252	1	100252	1	100252	1
118	SPRING LEVER GZ	610429	1	610429	1	610429	1	610429	1
119	LABEL OIL CHAIN	830502	2	830502	2	830502	2	830502	2
120	LABEL DANGER	900327	2	900327	2	900327	2	900327	2
121	NUT LOCK 5/16-24 SER HEX WSHR FLNG	440274	8	440274	8	440274	8	440274	8
122	LABEL CLUTCH DRIVE	500176	1	500176	1	500176	1	500176	1
123	EYEBOLT PIGTAIL 5/16"-18 X 1 1/4"	440280	1	440280	1	440280	1	440280	1
125	DIVERTER ASSY	440312	1	440312	1	440312	1	440312	1
126	LABEL AIM AND SHOOT	440332	1	440332	1	440332	1	440332	1